

NeuroMatrix® MC431 Single-DSP PCI Evaluation Board

MC431 is a Single-DSP PCI board designed for software evaluation and system prototyping on NM6403 DSP. MC431 is a low cost solution that can be used for learning NeuroMatrix® architecture and Software Development Kit. It has one NM6403 DSP, 4MB SRAM and two communication ports.

The NM6403 DSP has an access to two 2MB SRAM banks (one bank per each bus). Each bank is accessible for reading/writing both from the processor and from PCI bus. The MC431 has two external communication ports for connecting input/output devices.

Features:

- low cost high-performance vector-matrix engine – NM6403 DSP
- 4 MB SRAM
- Two I/O communication ports hardware compatible with TI 'C40 DSP
- PCI host interface

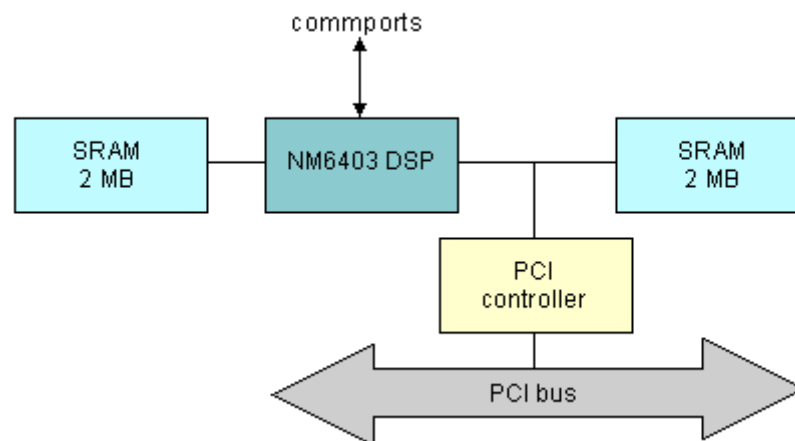
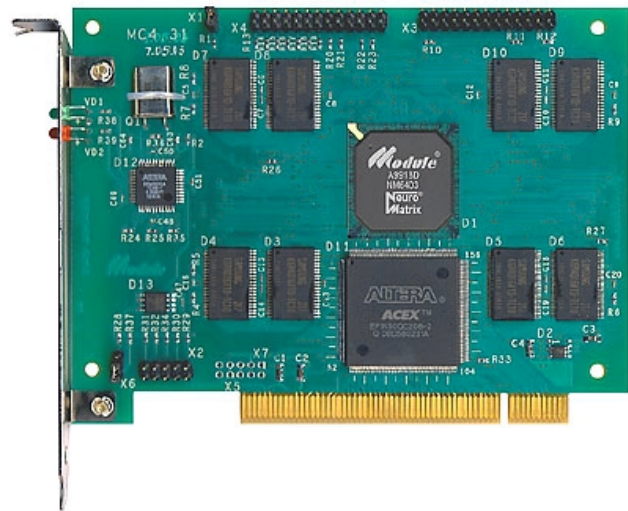

Fig.1. Functional Diagram

Applications:

- Digital Signal Processing
- Video-image processing
- Neural Networks
- Vector-matrix calculations

Support Software:

The NeuroMatrix® Software Development Kit (SDK) is a complete chain of software design and debugging tools:

- C++ compiler;
- Assembler;
- Linker;
- Librarian;
- C-source Debugger;
- Cycle accurate simulator;
- Drivers for Windows;
- C run-time library with source code;
- Load and exchange library;
- Example of using the Load and Exchange library.

Specifications:

Processor:	one 32/1-64-bit NeuroMatrix® NM6403 RISC/DSP processors
Performance:	Scalar operations for 32-bit data up to 120 MOPS (peak) Vector operations with 8-bit data up to 960 MMAC (peak)
Memory:	4 MB SRAM
Power:	supply 5.0V / 3.3V consumption approx. 2.0 W
Input/Output:	Two communication ports up to 15 MB/sec. throughput each PCI bus up to 132 MB/sec throughput
Design:	Half-size PCI board